

Tel.No.: 23544341.
Fax : 022- 23532737

Email : aiipmr@vsnl.com
Website : www.aiipmr.gov.in

भारत सरकार / Government of India
स्वास्थ्य एवं परिवार कल्याण मंत्रालय / Ministry of Health and Family Welfare

अखिल भारतीय भौतिक चिकित्सा एवं पुनर्वास संस्थान / ALL INDIA INSTITUTE OF PHYSICAL MEDICINE AND REHABILITATION
हाजी अली, के. के मार्ग, महालक्ष्मी, मुंबई- 400 034 / Haji Ali, K.K.Marg, Mahalaxmi, Mumbai – 400 034.

संदर्भ सं./ Ref.No.: पीडब्ल्यूएस/कोटेशन/PWS/Qtn./ 1734

दिनांक / Dated : 14th November, 2019

To,

कृपया पीछे देखिये,

महोदय / Sir,

निम्न प्रकार की उल्लिखित _____ खरीदी हेतु यह प्रस्तावित किया जाता है, जैसा कि नीचे बताया गया है।

It is proposed to purchase following Orthotic Knee Joints (Made up to of forged parts) – Size-III (As per our sample) as mentioned below.

मैं, अनुरोध करता हूँ कि उपर्युक्त आपूर्ति के लिए न्यूनतम दर प्रस्तुत करें।

You are requested to submit your lowest rate for supply of the same.

दरें बताते समय कृपया निम्नलिखित जानकारी दें :

While quoting, the following information may please be supplied :

1. वस्तुओं का पूर्ण विवरण-वस्तुओं को सचित्र स्पष्ट करनेवाली पुस्तिकाओं, इश्तेहारों या नमूनों के रूप में।

Complete description of the articles in form of booklets, pamphlets or samples illustrating the articles.

2. अवधि, जिसमें आपूर्ति कि जा सके।

The period within which the supply is to be made.

- 3- सामान्य एवं बिक्री कर / विक्रय कर संख्या इत्यादि, यदि लागू हों।

General and sales tax number etc. if applicable.

निविदा के लिए मुहरबंद लिफाफे में ऊपर 'निविदा' शीर्षक देकर निदेशक, अखिल भारतीय भौतिक चिकित्सा एवं पुनर्वास संस्थान, हाजी अली, मुंबई-400 034 को प्रस्तुत करें एवं स्थापना अनुभाग में उपलब्ध निविदा पेटी दिनांक **09/12/2019** में 3.30 बजे (अपराह्न) के पूर्व डालें।

The quotation should be submitted in sealed envelope superscribed as **quotation for _____** to the Director, All India Institute of Physical Medicine and Rehabilitation, Haji Ali Park, Mumbai- 400 034 and to be dropped in quotation Box available with Establishment Section before 3.30 P.M. (I.S.T.) on **09/12/2019** निविदा, केवल प्राधिकृत हस्ताक्षरकर्ता के नाम एवं पदनाम, पैन/टैन संख्या के साथ ही वैध मानी जाएगी।

Quotation with name & designation of authorized signatory by mentioning PAN/TAN and GST Number will only be valid.

निविदा केवल एक वर्ष की अवधि के लिए ही वैध होगी। आपूर्ति आदेश तिमाही जारी किया जाएगा।

Quotations should be valid for the period of one year. Supply Order will be placed as and when required.

इस संबंध में किसी प्रकार की अन्य जानकारी आवश्यक हो तो आप इस कार्यालय से सोमवार से शुक्रवार, 9.00 से (पूर्वाह्न) 3.30 (अपराह्न) बजे के बीच प्राप्त कर सकते हैं।

Any other information you may require in this matter can be had from this office from

Monday to Friday between 9.00 a.m. to 3.30 p.m.

Sr. No.	Name of the Material	Quantity
1	Orthotic Knee Joints (Made up to of forged parts) – Size-III (As per our sample)	100 Pairs

Made in India components will be preferred. BIS mark (certification) components will be preferred.

Detailed Technical Specification and drawing separately attached.

भवदीय / Yours faithfully,

Sd/-

व्याख्याता, संयुक्तांग एवं ऋज्वांग,
(Lecturer, Prosthetic & Orthotic)

सूचना : पूर्व रसीदी बिल के तीन प्रतियों के अनुसार भुगतान, किया जाएगा।

Note : Payment will be made against pre-receipted bill in triplicate.



Indian Standard

(Reaffirmed 2002)

(Reaffirmed 2012)

(Reaffirmed 2017)

SPECIFICATION FOR KNEE JOINT WITH LOCK FOR ORTHOSIS

(First Revision)

1. **Scope** — Prescribes dimensional and other requirements for knee joint with lock for steel orthopaedic calipers and braces.
2. **Shape and Dimensions** — As shown in Fig. 1 and 2.

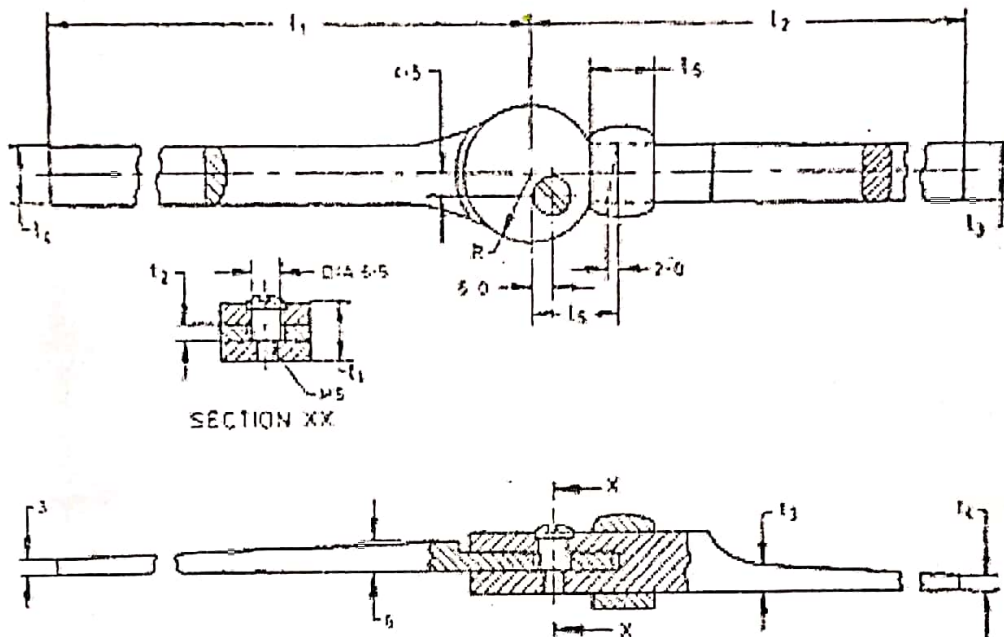

Size	l_1	l_2	l_3	l_4	l_5	l_6	t_1	t_2	t_3	t_4	t_5
I	260	220	11	11	18	13	10	3	4	3.0	13
II	300	260	13	13	20	15	12	4	5	3.5	15
III	340	300	13	13	20	16	14	4	6	4.0	15

Note — A complete caliper or brace requires one joint as shown in this figure and one joint made to opposite hand and as in Fig. 2.

All dimensions in millimetres.

FIG. 1 KNEE JOINT WITH LOCK FOR STEEL ORTHOPAEDIC CALIPER AND BRACES

3. **Material** — Carbon steel conforming to Designation 30 C8 or 35 C4 of IS : 1570 (Part 2)-1979 'Schedules for wrought steels: Part 2 Carbon steels (unalloyed steels) (first revision)'.

4. **Workmanship and Finish** — The male and female parts of joint shall be accurately and cleanly machined and the joint faces shall be finished clean and free from toolmarks. Fabrication by welding or brazing shall not be allowed. The male part shall have a close running fit with the female joint member. The outside surfaces of the joint and the shanks shall be free from forging scales. All sharp edges and corners shall be rounded. The component shall be free from surface flaws and cracks. The ring catch shall have a close sliding fit on the rectangular section of the female joint member. There shall not be any frictional, jerky or mediolateral movements at the joints.

5. **Marking** — The joint shall be marked with the following:
 - a) Manufacturer's name, initials or recognized trade-mark, and
 - b) Size of the joint.

Adopted 21 May 1986

© February 1987, ISI

Gr 1

INDIAN STANDARDS INSTITUTION
MANAK BHAVAN, 9 BANADUR SHAH ZAFAR MARG
NEW DELHI 110002

890

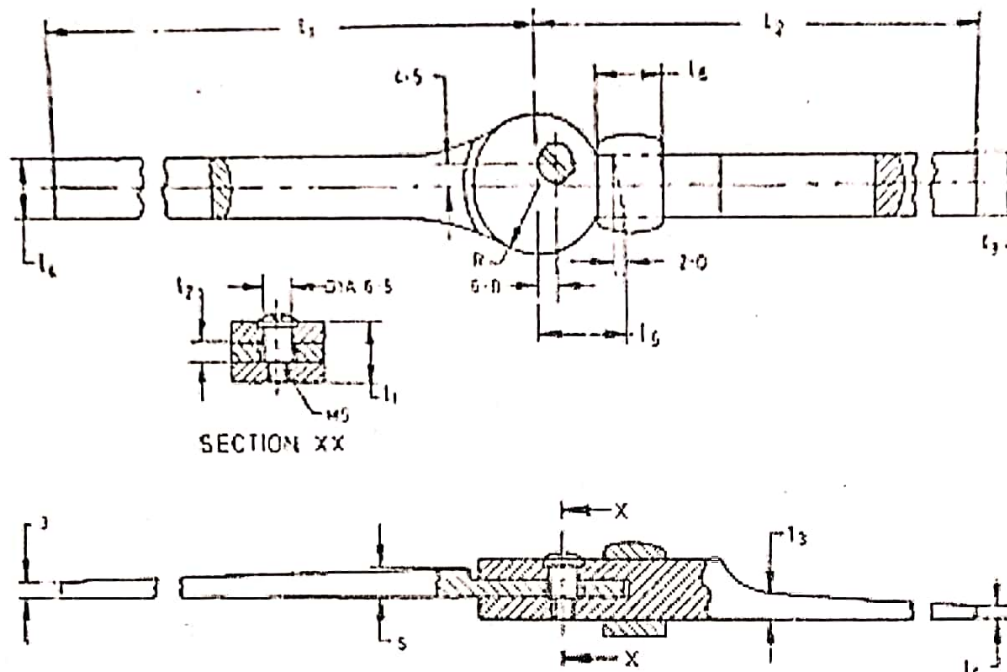

Size	l_1	l_2	l_3	l_4	l_5	l_6	l_7	l_8	l_9	l_{10}	l_{11}	l_{12}	l_{13}	l_{14}	R
I	250	220	11	11	18	13	10	3	4	3	3	13			13
II	300	260	13	13	20	15	12	4	5	3.5	3.5	15			15
III	340	300	13	15	20	16	14	4	6	4	4	15			15

Note — A complete caliper or brace requires one joint as shown in this figure and one joint made to opposite hand and as in Fig. 1.

All dimensions in millimetres.

FIG. 2 KNEE JOINT WITH LOCK FOR STEEL ORTHOPAEDIC CALIPER AND BRACES

5.1 *ISI Certification Marking* — Details available with the Indian Standards Institution.

6. *Packing* — As agreed to between the purchaser and the supplier.

7. *Sampling* — A sampling scheme and criteria for acceptance shall be as agreed to between the purchaser and the manufacturer. However, a recommended scheme is given below.

7.1 *Lot* — All the sets of knee joints of the same type shall be grouped together to constitute a lot. Each lot shall be tested for the requirements of this specification.

7.2 Each set of knee joint with lock for orthosis shall be examined for shape and dimensions (2) and workmanship and finish (4). All those sets which fail in one or more of the above requirements shall be rejected and only the satisfactory sets of joints shall be accepted.

Handwritten signature and date: 17/10/2019

Handwritten text in Hindi: श्री ०. सी. शर्मा, अध्यक्ष, राष्ट्रीय प्रथम श्रेणी के अर्थोसिस्टिक उपकरणों के लिए भारतीय मानक ब्यूरो, नई दिल्ली-110002।

EXPLANATORY NOTE

In this revision, the main changes are in Fig. 1 and 2 and dimensions.